



RINSE-O-MATIC®

Powerfully Rinses Blender Containers

No more rinsing containers by hand or letting the water run; the Rinse-o-matic is the more efficient way to rinse any blender container* in seconds! Just place the container upside down and the high water pressure rinses residue away, saving you time and money.

Smart Product Design

- Powerful spray forcefully removes stubborn residue
- Only sprays when pressure is applied for ease-of-use
- Durable ABS plastic construction is virtually unbreakable and verified to perform more than 1,000,000 cycles
- Fits on any standard faucet and no electricity is required

** 2.0 L containers or smaller from most manufacturers.*



Product Specifications

Rinse-o-matic® Item No. 1420

Pack: Includes Rinse-o-matic blender container rinser, includes base, 1 extra sprayhead assembly, 76,2 cm hose assembly, Y connector, faucet adapters and instructions.

Net Weight: 0,7 kg (1,0 kg with box)

Dimensions: 34,5 x 14,0 cm (H x W x D)

Warranty: Please contact your authorized Vitamix distributor for warranty information.

For more information, please contact an authorized Vitamix distributor, or Vitamix international customer service.

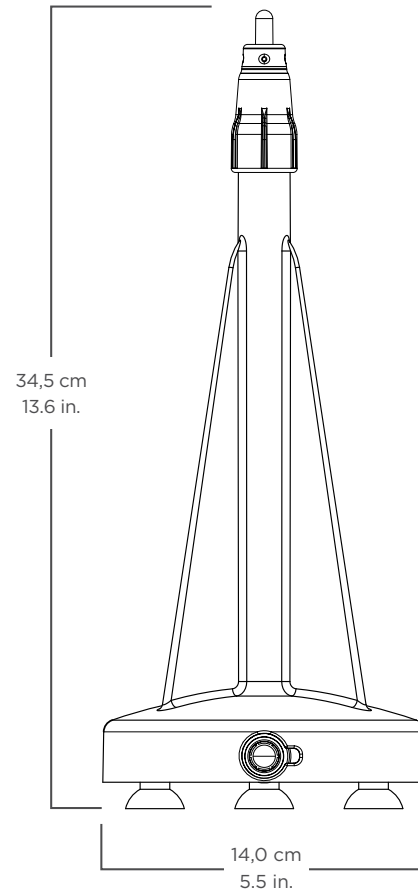

Where applicable:



Contact Information

U.S.A., Canada & Latin America:

Tel: 800.4DRINK4 or
440.235.0214

E-mail: foodservice@vitamix.com

www.vitamix.com/foodservice

Vita-Mix Corporation
8615 Usher Road
Cleveland, OH 44138-2103 U.S.A.

Outside of U.S.A., Canada &
Latin America:

Tel: +1.440.782.2450

E-mail: international@vitamix.com

For more information, contact your
local foodservice distributor.